

# *Instruments and Related Topics*

---

## *1. Traveling Microscope*

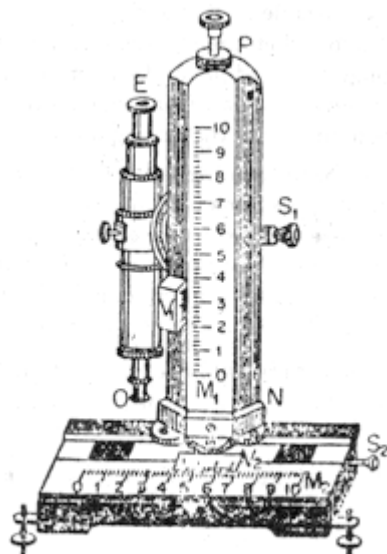

Fig. 1 Traveling Microscope

The traveling microscope [Fig.1] is an instrument well-suited for the purpose of measuring small vertical or horizontal distances with high accuracy. It consists of a compound microscope that is capable of independent horizontal and vertical movements. The amount of movement in the vertical direction can be obtained from the scale  $M_1$  and the vernier  $V_1$  whereas that in the horizontal direction can be obtained from the scale  $M_2$  and the vernier  $V_2$ . The microscope may be raised or lowered along a vertical pillar PN and its axis may be fixed horizontally, vertically, or in between them by the screw  $S_1$ . The screw  $S_2$  is used to move the pillar PN horizontally. The object is viewed through the eye piece E when the objective lens O is turned towards the object. The focal length of the objective generally lies between 3 to 4 cm. The focusing of the microscope is accomplished by a screw attached to the body of the microscope. The cross-wire of the eye piece is focused by moving the eye piece in or out. Four screws at the base of the instrument are used for its leveling.

Before using the instrument note the vernier constants of both the verniers  $V_1$  and  $V_2$ . Generally the vernier constants of  $V_1$  and  $V_2$  are the same.

The procedure to measure the horizontal or the vertical distance between two points is as follows:

- (i) Level the instrument with the help of the base screws and a spirit level.
- (ii) View one of the points through the microscope and focus the cross-wire with the image of the point. Note the readings of the main scale (m.s.) and the vernier scale (v.s.).
- (iii) Displace the microscope vertically or horizontally, as required, by means of the screw  $S_1$  or  $S_2$  to view the second point and focus the cross-wire with the image of the second point. Note again the readings of the main scale and the vernier scale.
- (iv) Calculate the difference (horizontal or vertical) between these two readings to obtain the distance between the points.

## *2. Optical Bench*

There are two types of optical bench: (i) *ordinary* and (ii) *accurate* types. We describe below the second type, because this is used in the experiment using biprism. The first type is a simple one and is used for measurements of optical constants of mirrors and lenses. A student, acquainted with the accurate type of optical bench, will be able to handle the ordinary type easily.

The optical bench employed for biprism work is shown in Fig. 2. It consists of two long horizontal steel rails,  $R_1R_2$  and  $R_3R_4$ , placed at a fixed distance apart. On one of these rails, a scale is graduated in mm. This is shown in Fig.2 on the rail  $R_1R_2$ . Several uprights, such as  $U_1$ ,  $U_2$ ,  $U_3$ ,  $U_4$  having verniers  $V_1$ ,  $V_2$ ,  $V_3$  and  $V_4$  respectively attached to their bases, can slide over the rails. From the scale and the vernier, the shift of any upright from any position can be determined. The height of the uprights from the bed of the bench can be adjusted; the bed can be made horizontal by the leveling screws,  $L_1$ ,  $L_2$ ,  $L_3$  and  $L_4$ . The screw represented by  $L_4$  is not seen in the figure.

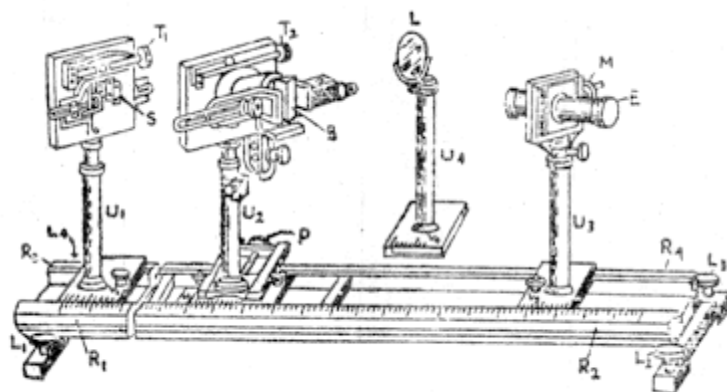

Fig. 2 Optical Bench

[  $L_1$ ,  $L_2$ ,  $L_3$  &  $L_4$  (The screw represented by  $L_4$  is not seen) are four leveling screws;  $R_1R_2$  &  $R_3R_4$  are two horizontal steel rails;  $U_1$  is the upright carrying the slit  $S$ ,  $U_2$  is the upright carrying the biprism  $B$ ,  $U_3$  is the upright carrying the micrometer eye-piece  $E$ , and  $U_4$  is the upright carrying a convex lens  $L$ ;  $V_1$ ,  $V_2$ ,  $V_3$  and  $V_4$  are four verniers attached to the 1<sup>st</sup>, 2<sup>nd</sup>, 3<sup>rd</sup> and 4<sup>th</sup> uprights respectively;  $T_1$  and  $T_2$  are two tangent screws by which the slit and the biprism can be rotated in their planes about a horizontal axis,  $M$  is a micrometer screw provided with a circular and a linear scale; the screw attached to the upright  $U_2$  can move the upright perpendicular to the bench.]

The upright  $U_1$ , placed near the zero of the scale, carries the slit  $S$ . The upright  $U_2$  carries the biprism  $B$ . The slit and the biprism can be rotated in their own planes about a horizontal axis by the tangent screws  $T_1$  and  $T_2$ , respectively. They can also be rotated about a vertical axis. The upright  $U_2$  can be moved perpendicular to the bench by the screw  $P$ .

The upright  $U_3$  is mounted on the other end of the bench and carries the micrometer eye-piece  $E$ .  $M$  is the micrometer screw provided with a linear and a circular scale. By this screw, the eye-piece can be moved perpendicular to the bench. The upright  $U_3$  can also be moved perpendicular to the bench.

The upright  $U_4$  carries a convex lens  $L$ , and can be placed between the biprism and the eye-piece.

***Index error*** : The distance between any two stands, as obtained from the difference of the bench scale readings, may not be the true distance between them. Thus, an error, known as *index error*, may exist between any two stands. If  $l$  be the actual distance between the two stands and  $d$  be the distance obtained from the bench scale readings, then the index error is given by  $x=l-d$ . This is to be added algebraically to the quantity to be corrected for index error. When the distances are

measured from the center of an equi-convex lens of thickness  $t$ , the index error becomes  $\left(1 - d + \frac{t}{2}\right)$ .

### 3. Parallax

Let an eye E be placed in a straight line joining two object points O and O', as shown in Fig.3. Now if the eye is moved in a direction perpendicular to the line EOO', then the more distant object O' will appear to move with the eye. This phenomenon is known as parallax. To eliminate parallax, either the nearer object O should be moved away from the eye E, or the distant object O' should be moved towards the eye until there is no separation between them as the eye is moved in a direction perpendicular to the line joining the two objects.

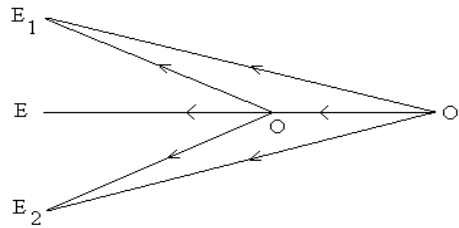

Fig. 3 Ray diagram for parallax error

### 4. Spectrometer

This instrument [Fig.4] is normally used to study spectra and to measure refractive indices. It has the following essential parts :

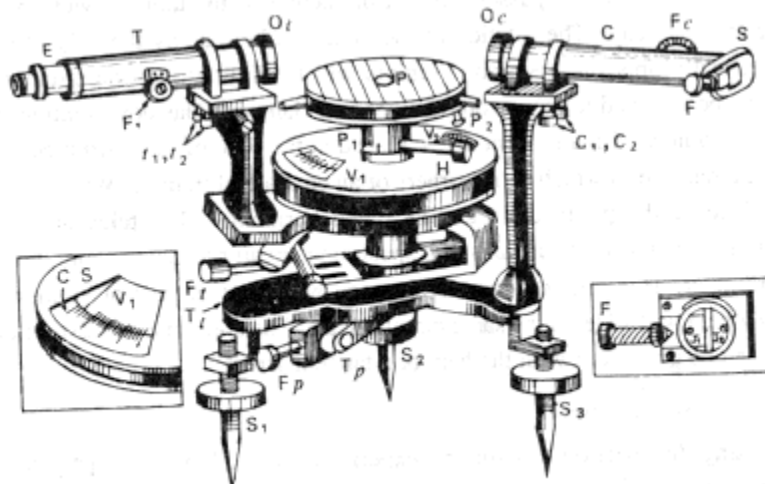

Fig. 4 The Spectrometer

T, telescope; E, the eye-piece; O<sub>t</sub> its objective; F<sub>t</sub>, its focusing screw; t<sub>1</sub>, t<sub>2</sub> levelling screws for telescope, P<sub>1</sub>, P<sub>2</sub>, two of the leveling screws of the prism table; P, prism table; C, collimator; O<sub>c</sub>, its lens; F<sub>c</sub>, its focusing screw; S, slit, F, screw for adjusting width of slit, C<sub>1</sub>, C<sub>2</sub>, leveling screws for collimator, F<sub>t</sub> screw for giving motion to telescope; T<sub>p</sub>, tangent screw for prism table; F<sub>p</sub>, fixing screw for prism table; T<sub>p</sub>, tangent screw for prism table; S<sub>1</sub>, S<sub>2</sub>, S<sub>3</sub>, leveling screws; C.S., circular scale; V<sub>1</sub>, V<sub>2</sub>, vernier scales; H, screw for fixing the prism table to the verniers J<sub>1</sub>, J<sub>2</sub>, parallel jaws of the slit.

(i) **The collimator (C)** : It consists of a horizontal tube with a converging achromatic lens  $O_c$  at one end of the tube and a vertical slit S (shown separately in the right side of Fig. ) of adjustable width at the other end. The slit can be moved in or out of the tube by a rack and pinion arrangement  $F_c$  and its width can be adjusted by turning the screw F. The collimator is rigidly fixed to the main part of the instrument and can be made exactly horizontal by two screws  $C_1$  and  $C_2$  below it. When properly focused, the slit lies in the focal plane of the lens  $O_c$ . Thus the collimator provides a parallel beam of light.

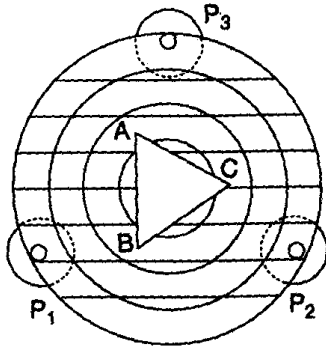

Fig. 5 Prism Table

(ii) **The prism table (P)** : It is a small circular table and capable of rotation about a vertical axis. It is provided with three leveling screws, shown separately in Fig.5, as  $P_1$ ,  $P_2$  and  $P_3$ . On the surface of the prism table, a set of parallel, equidistant lines parallel to the line joining two of the leveling screws, is ruled. Also, a series of concentric circles with the center of the table as their common center is ruled on the surface.

The screw H (Fig.4) fixes the prism table to the two verniers  $V_1$  and  $V_2$  and also keeps it at a given height. These two verniers rotate with the table over a circular scale graduated in half degrees. Then angle of rotation of the prism table can be recorded by these two verniers. The screw  $F_p$  fixes the prism table and the screw  $T_p$  is the tangent screw for the prism table by which a smaller rotation can be imparted to it. It should be noted that a tangent screw functions only after the corresponding fixing screw is tightened.

(iii) **The telescope (T)** : It is a small astronomical telescope with an achromatic doublet as the objective  $O_t$  and the Ramsden type eye-piece E. The eye-piece is fitted with cross-wires and slides in a tube which carries the cross-wires. The tube carrying the cross-wires, in turn, slides in another tube which carries the objective. The distance between the objective and the cross-wires can be adjusted by a rack and pinion arrangement  $F_1$ . The telescope can be made exactly horizontal by two screws  $t_1$  and  $t_2$ . It can be rotated about the vertical axis of the instrument and may be fixed at a given position by means of the screw  $F_t$ . A slow motion can be imparted to the telescope by the tangent screw  $T_t$ .

(iv) **The circular scale (C.S)** : This is shown separately in the left hand side of Fig.4. It is graduated in degrees and coaxial with the axis of rotation of the prism table and the telescope. The circular scale is rigidly attached to the telescope and turned with it. A separate circular plate mounted coaxially with the circular scale carries two verniers,  $V_1$  and  $V_2$ ,  $180^\circ$  apart. When the prism table is clamped to the spindle of this circular plate, the prism table and the verniers turn together.

The whole instrument is supported on a base provided with three leveling screws  $S_1$ ,  $S_2$  and  $S_3$ . One of these is situated below the collimator. In Fig. 4, this screw has been called  $S_3$ .

#### **4.1 Adjustments of the Spectrometer**

The following essential adjustments are to be made step by step in a spectrometer experiment :

(i) **Leveling** : Leveling the apparatus means making (a) the axis of rotation of the telescope vertical, (b) the axis of the telescope and that of the collimator horizontal, and (c) the top of the prism table horizontal. The following operations are performed for the purpose.

(a) **Leveling the telescope** : Place a spirit level on the telescope tube T making its axis parallel to that of the telescope. Set the telescope parallel to the line joining the leveling screws  $S_1$  and  $S_2$ . Bring the air bubble of the spirit level halfway towards the center by turning the screws  $S_1$  and  $S_2$  by equal amounts in the opposite directions. Next bring the bubble at the center by turning the leveling screws  $t_1$  and  $t_2$  below the telescope by equal amounts in opposite directions.

Now rotate the telescope through  $180^\circ$  so that it is placed parallel to its first position on the other side. Bring the air bubble at the center as before, i.e. half by the screws  $S_1$  and  $S_2$  and the other half by  $t_1$  and  $t_2$ . Repeat the operations several times so that the bubble remains at the center for both positions of the telescope.

Next place the telescope in line with the collimator and bring the air bubble of the spirit level at the center by turning the screw below the collimator, i.e.  $S_3$ . Check the first adjustment after this second one is made. The axis of rotation of the telescope has thus become vertical and the axis of the telescope has become horizontal.

(b) **Leveling the collimator** : Remove the spirit level from the telescope. Place it on the collimator along its length. Bring the air bubble of the spirit level at the center by adjusting the leveling screws  $C_1$  and  $C_2$  below the collimator. This makes the axis of the collimator horizontal.

(c) **Leveling the prism table** : Place a spirit level at the center of the prism table and parallel to the line joining two of the leveling screws of the prism table. Bring the air bubble of the spirit level at the center by turning these two screws in the opposite directions. Now place the spirit level perpendicular to the line joining the two screws and bring the bubble at the center by adjusting the third screw. This makes the top of the prism table horizontal.

(ii) **Alignment of the source** : Place the Bunsen burner at a distance of 15 to 20 cm from the slit in such a way that the axis of the collimator passes through the center of the flame. Soak the asbestos wound round the iron or copper ring in a concentrated solution of sodium chloride. Place the ring round the flame at such a height that the brightest part of the flame lies opposite to the slit.

Now place a screen with an aperture between the source and the slit so that light from the source can reach the slit without obstruction while, at the same time, stray light is prevented from reaching the observer's eyes directly.

(iii) **Focusing the cross-wires** : Rotate the telescope towards any illuminated background. On looking through the eye-piece, you will probably find the cross-wires blurred. Move the eye-piece inwards or outwards until the cross-wires appear distinct.

(iv) **Adjustment of the slit** : Place the telescope in line with the collimator. Look into the eye-piece. The image of the slit may appear blurred. Make the image very sharp by turning the focusing screw of the telescope and of the collimator, if necessary. If the image does not appear vertical, make it vertical by turning the slit in its own plane. Adjust the width of the slit so that its image may have a breadth of about one millimeter.

(v) **Focusing for parallel rays: Schuster's method**: This is the best method of focusing the telescope and the collimator for parallel rays within the space available in the dark room. The method is explained below.

Place the prism on the prism table with its center coinciding with the center of the table and with its refracting edge vertical. Rotate the prism table so that one of the refracting faces of the prism AB (Fig.6) is directed towards the collimator and light from the collimator is incident on the refracting face at an angle of about  $45^\circ$  to the face. Look through the other face AC of the prism for the refracted beam which is bent towards the base of the prism.

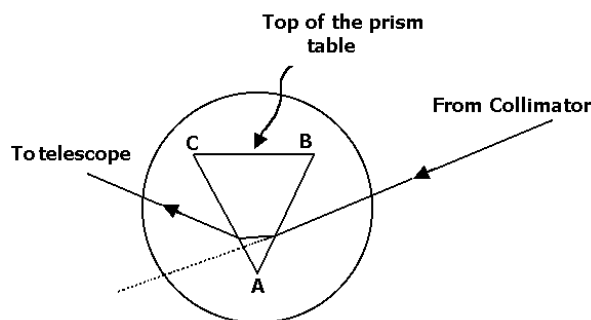

Fig. 6 Focusing for parallel rays

You will see with the naked eye the image of the slit formed by refraction through the prism. Slightly rotating the prism table, first in one direction and then in the other, you will also see that the image moves. Now turn the prism table in the proper direction so that the image of the slit moves towards the direct path of rays from the collimator and reaches the position of minimum deviation. At this position of the prism, the image will move away from the direct path of rays in whatever direction the prism table is turned. Next bring the telescope between the prism and the eye and move it slightly this way or that so that you can see the image of the slit in it. Slightly rotate the prism table so that you find the image through the telescope exactly at the position of minimum deviation. Displace the telescope from this position in a direction away from the direct path of rays. For this position of the telescope, the image of the slit can be brought on the cross-wires for two positions of the prism. In one position, the angle of incidence of the prism is larger than that at

minimum deviation and in the other position it is smaller. In the former position, the refracting edge of the prism is nearer to you than at minimum deviation, and in the latter it is more remote from you. The former position of the prism is called the slant position and the latter position is called the normal position. Next perform the following operations :

(a) Bring the image on the cross-wires of the telescope by rotating the prism table in such a way that the refracting edge of prism is nearer to you (the prism is at the slant position) than at minimum deviation. Focus the image by rack and pinion arrangement of the telescope, i.e. the instrument nearer to you. The image now becomes very narrow.

(b) Next rotate the prism table in the opposite direction. The refracting edge of the prism will move away from you. Go on rotating the prism table until the image, moving towards the position of minimum deviation, turns back and reaches the cross-wires again. Keeping the prism at this position, i.e. at the normal position, focus the image by the rack and pinion arrangement of the collimator, i.e., the instrument away from you. The image is now very wide.

Repeat the operations (a) and (b) several times in succession till the image remains sharp for both the positions of the prism. The telescope and the collimator are then focused for parallel rays.

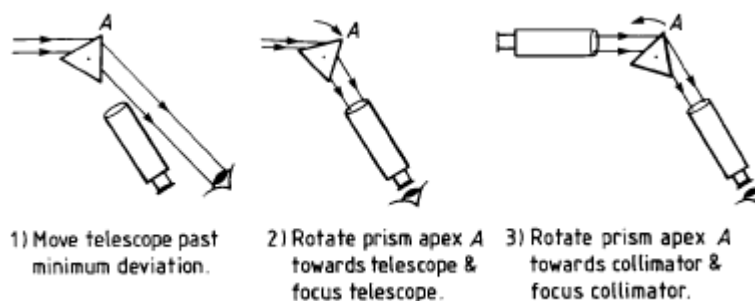

Fig.7 Schuster's method

**Mnemonic :** The operations in Schuster's method can be easily remembered as follows : When the refracting edge of the prism is nearer to you, focus the image by the telescope, i.e. The instrument nearer to you. When the refracting edge of the prism is away from you, focus by the collimator, i.e. the instrument away from you. Or simply, near-near, away-away. Alternatively, the operations can be remembered by noting that when the image is Broad, focusing is done by the Collimator. When the image is Thin, focus by the Telescope. Easy way to remember, b-c, t-t.

#### **4.2 Theory of Schuster's method**

When a narrow beam of light is incident on one face (AB) of a prism, the emergent beam from the other face (AC) appears to come from a point image I [Fig.8(a)].

The relation between the distance  $v$  of the image from the prism and that of the object  $u$  is given by

$$v = \frac{u \left( \frac{\cos^2 i'}{\cos^2 r'} \right)}{\left( \frac{\cos^2 i}{\cos^2 r} \right)} \dots(i)$$

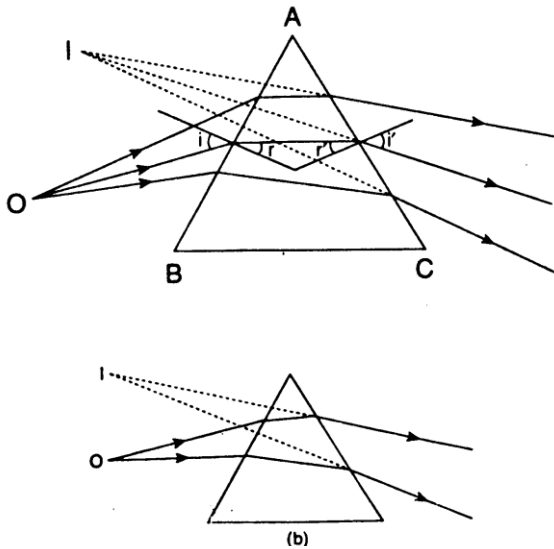

Fig.8 Schuster's method (a) General position (b) Minimum deviation position

where  $i$  and  $r$  are respectively the angles of incidence and refraction at the first face, and  $i'$  and  $r'$  are those at the second face.

When the prism is at the position of minimum deviation for the mean ray of the beam,  $i = i'$  and  $r = r'$ . In the case,  $v = u$ ,

i.e. the distance of the image from the prism is equal to the distance of the object. This shown in Fig. 8(b).

When the prism is at the normal position, the angle of incidence is smaller than that at minimum deviation. Under this condition,  $i < i'$ , and  $\frac{\cos^2 i}{\cos^2 r} > \frac{\cos^2 i'}{\cos^2 r'}$ . Thus  $v < u$ , i.e. the image is nearer to the prism than the object [Fig. 9(a)].

Similarly it can be shown that for the slant position of the prism when the angle of incidence is larger than that at minimum deviation,  $v > u$ , i.e. the image of the slit formed by refraction at the prism is at a longer distance than the object [Fig. 9(b)].

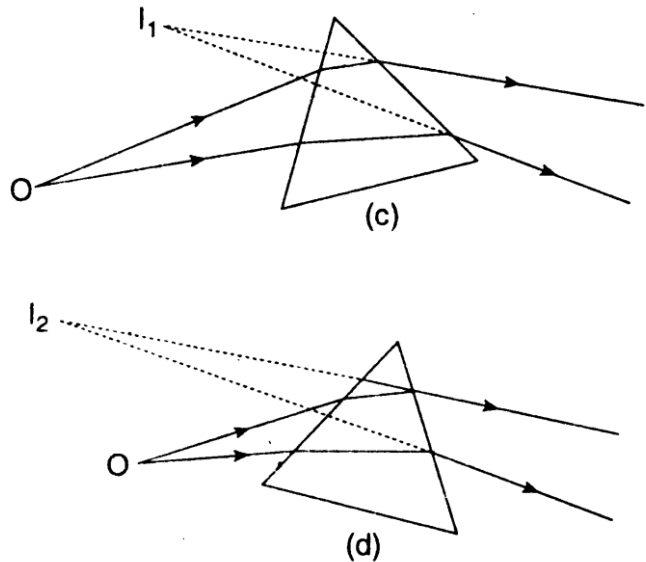

Fig. 9 Schusters's method (a) Normal position (b) Slant position

Now in operation (a) of 4.1(v), when the prism is in the slant position, the image of the slit is focused in the telescope by its rack and pinion arrangement. This means that the telescope is focused on a remote point (since the image is formed at a greater distance from the object). Next in operation (b) when the prism is turned to the normal position, the image moves nearer to the prism and goes out of focus of the telescope. This time, when the image is focused in the telescope by moving the

collimator lens nearer to the slit, the image is pushed to the previous position of focus of the telescope. If the prism is now changed from the normal to the slant position (as is done when the operation (a) is again repeated), the image moves further away from the prism. When this image is focused by the telescope, the telescope is focused on a more remote point.

Thus with every adjustment of the collimator, the image formed by refraction at the prism at the normal position is pushed at the position corresponding to the slant position of the prism and in the latter position the telescope is focused on the point which moves away to greater and greater distances. Ultimately the images corresponding to the two positions of the prism are formed at very great distances and appear to be in focus for both positions of the prism. The spectrometer is thus focused for parallel rays.

### ***5. Optical Leveling of a Prism***

The leveling of a prism table by the method discussed in 4.1(i)(c) makes the refracting faces of the prism vertical only when the bottom face of the prism, which is placed on the prism table, is perpendicular to its three edges. But if the bottom face is not exactly perpendicular to the edges, which is actually the case, the prism should be leveled by the optical method as described below.

- (i) Illuminate the slit by sodium light and place the telescope with its axis making an angle of about  $90^\circ$  with that of the collimator.
- (ii) Place the prism on the prism table with its center coinciding with that of the table and with one of its faces (face AB in Fig. 5) perpendicular to the line joining the two screws  $P_1$  and  $P_2$  and of the prism table.
- (iii) Rotate the prism table till the light reflected from this face AB of the prism enters the telescope. Look through the telescope and bring the image at the center of the field of the telescope by turning the screws  $P_1$  and  $P_2$  equally in the opposite directions.
- (iv) Next rotate the prism table till the light reflected from the other face AC of the prism enters the telescope, and bring the image at the center of the field by turning the third screw  $P_3$  of the prism table.

#### ***Care in handling the prism***

The refracting surfaces of the prism should be cleaned with a piece of cloth soaked in alcohol. Do not touch the refracting surfaces by hand. Place the prism on the prism table or remove it from the prism table by holding it with fingers at the top and bottom faces.

### ***6. Discharge Tubes***

A discharge tube is an experimental arrangement to produce electrical discharge through gases at low pressures. In its simplest form, it consists of a closed

glass tube about 30 cm long and 4 cm in diameter, as shown in Fig.10. The tube is provided with two metal electrodes A and C and a side tap T.

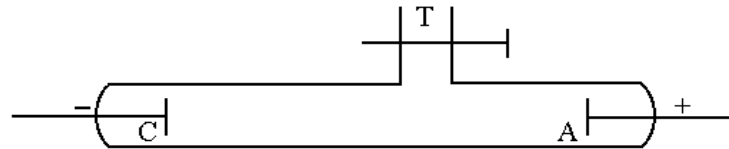
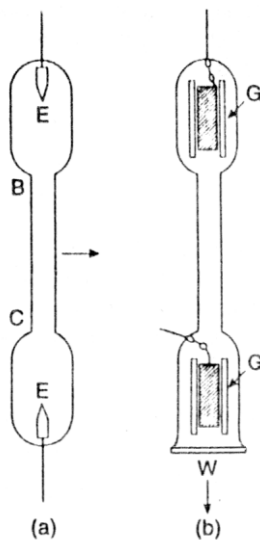

Fig. 10 Discharge tube

The two electrodes are connected to the secondary of a powerful induction coil which can give a high potential difference of the order of 50 kilovolt or more. The electrodes A and C which are connected respectively to the positive and negative terminals of the secondary are termed the anode and the cathode. The tube is connected to a high vacuum pump and a pressure gauge through the side tap T.



***Geissler tubes***

Geissler tubes are discharge tubes used as a source of light in spectrum analysis. There are two common types of Geissler tubes, illustrated in Fig.11 (a) and (b). Type (a) is a straight glass tube having a capillary portion BC about 7 or 8 cm long with a bore of about 1 mm. The electrodes E, E, of this type are short pieces of aluminium rod, fused on to the ends of tungsten wires which are sealed through the glass. The tube is filled with gas or vapour at a pressure of 1 or 2 mm of mercury. A high potential exceeding 2000 volt is applied between the electrodes by means of an induction coil.

The gas or vapour emits its characteristic light which is most intense in the capillary portion BC, since the current density is greatest there. The light is observed laterally, as

Fig. 11 Geissler tubes

indicated by the arrow. This type of Geissler tube is used where maximum intensity is not required, or the tube is to be operated with a small induction coil. Type (b), known as 'end on', type, gives considerably great intensity. Here the electrodes are made up of aluminum sheets, rolled up and placed inside two loosely fitted inner glass tubes, G,G. They are connected to the tungsten wires by wrapping a small piece of aluminum at one end around the wire and pressing it tightly. Because of the larger area of the electrodes, greater

currents can be used without overheating the electrodes. The light is observed through a glass or quartz window, W, fixed at one end. In this direction, the light is most intense owing to the considerable dept of the glowing gas. The deposition of aluminum on the walls of the main tube, which occurs rather rapidly at a low pressure, is prevented by the inner glass tubes.

## 7. Polarimeter

A polarimeter is an apparatus or arrangement employed to find the specific rotation of an active solution or the concentration of the solution. The arrangement is shown in Fig. 12. It consists of three tubes,  $T_1$ ,  $T$  and  $T_2$  having their axes on the same horizontal straight line. The tube  $T_1$  contains a slit  $S$  placed at the focal plane of the collimating lens  $L$  which renders the rays from the slit parallel. The width and the position of the slit can be altered. The tube  $T_1$  also contains a polarizing Nicol  $P$  and a half-shade plate or biquartz  $H$ . The parallel beam of light from the lens  $L$  is plane-polarized by the Nicol  $P$  before passing out through the half-shade plate.

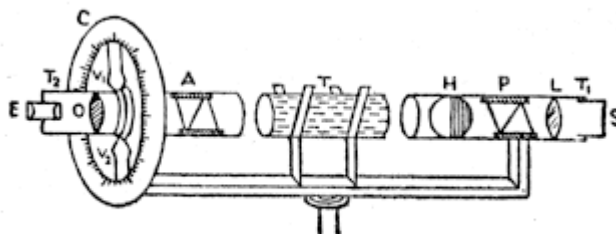

Fig. 12 The polarimeter

The second tube  $T$  is placed on a frame and contains the distilled water or the active solution.

The third tube  $T_1$  contains an analyzing Nicol  $A$  and an observing telescope. In the figure,  $O$  and  $E$  represent respectively the objective and the eye-piece of this telescope. Two verniers,  $V_1$  and  $V_2$  are attached,  $180^\circ$  apart, to the tube  $T_2$ . When the tube rotates, these verniers rotate on a circular scale  $C$ .

## 8. Nicol Prism

Refer any book on Optics.

- i) Fundamental of Optics, by F.A. Jenkins and H.E. White Pg.510
- ii) Optics by A. Ghatak Pg. 505
- iii) Optics by E. Hecht Pg. 237

## 9. Half-Shade Plate

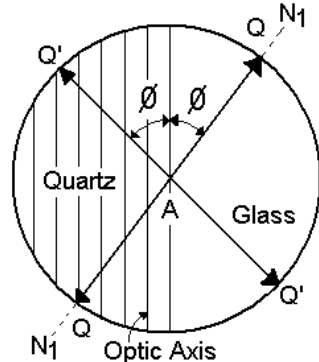

Fig. 13. Half shade plate

The half shade plate is a circular plate, one half of which is made of quartz and the other half is glass. It is a circular plate formed by cementing together along their diameters, semi-circular pieces of quartz and glass. One-half of the field of view is illuminated by vibrations of light emerging from the quartz and the other half simply by vibrations of light emerging from the glass. This is accomplished by the action of quartz plate in altering the plane of vibration of incident light.

The plate consists of a semi-circular plate of quartz cut with faces parallel to the optic axis and is of such a thickness that a relative phase difference of  $\pi$  or a path difference of  $\pi/2$  is introduced between the ordinary and extraordinary rays in

transmission normally through it. Thus it is simply a half wave plate. A semi-circular sheet of glass whose optical thickness is equal to that of the half-wave plate constitutes the other half of the plate. Consequently, the transmitted light through it has the same intensity as that emergent from the quartz portion.

To explain its action in dividing the field of view into two halves, let us suppose that  $N_1AN_1$  represents the principal section of the polariser, inclined at an angle  $\phi$ , to the optic axis.  $QAQ$  therefore represents the direction of vibrations in the light waves from the polariser and incident normally on glass-quartz combination. Glass is not doubly refracting. Therefore,  $QAQ$  also represents the vibrations emerging from the glass portion.

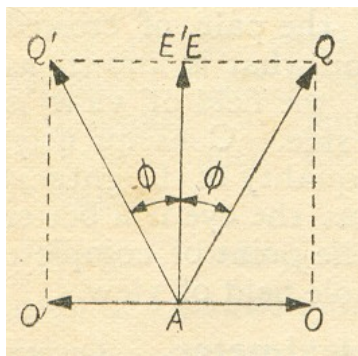

Fig. 14. Propagation of light in half shade plate

But quartz is a doubly refracting crystal. Therefore, the incident vibration  $QAQ$ , just on entering the crystal, is resolved into two components,  $AE$  (extraordinary ray) and  $AO$  (ordinary ray) respectively, along and perpendicular to the optic axis. These components are initially in phase with each other. But the speed of  $O$  ray is greater than that of  $E$  ray within quartz crystal. Therefore, as the waves advance inside the plate, the phase of the component  $AO$  ( $O$  ray) gradually advances over that of  $AE$ , and the thickness of quartz portion is such that at the point of emergence, the phase has exactly advanced by  $\pi$ . Geometrically, this advance in phase can be represented as shown in Fig. 14. On emergence, if  $E$  component is represented by  $AE'$  the  $O$  component must be represented by  $AO'$ , being turned through  $\pi$  (advance in phase) from its initial position  $AO$ . The resultant of  $AO'$  and  $AE'$ , is obviously  $AQ'$ . Thus  $AQ'$  represents the direction of vibration in the light waves emerging from the quartz portion of Laurent's plate the angle of rotation of the plane of vibration is obviously  $2\phi$ .

The light vibrations emerging from the glass and the quartz portions may be now analyzed by the second Nicol with its principal section along  $NAN$ , then their components  $AE$  and  $AE'$  along  $NAN$  are transmitted as  $E$  vibrations while the perpendicular components are totally reflected as  $O$  vibrations within the analyzing Nicol. Since  $AQ$  and  $AQ'$  are equally inclined to  $NAN$  [Fig. 15b] the transmitted amplitudes  $AE$  and  $AE'$  are equal and hence the two halves of the field appear equally bright. A slight rotation of the analyser from this setting say, in the clockwise direction [Fig. 15a] causes rapid increment in the transmitted portion  $AE'$  for quartz and decrement in the transmitted portion  $AE$  for glass. Quartz portion, therefore, appears brighter than the glass. On the other hand, a slight rotation of the analyser in

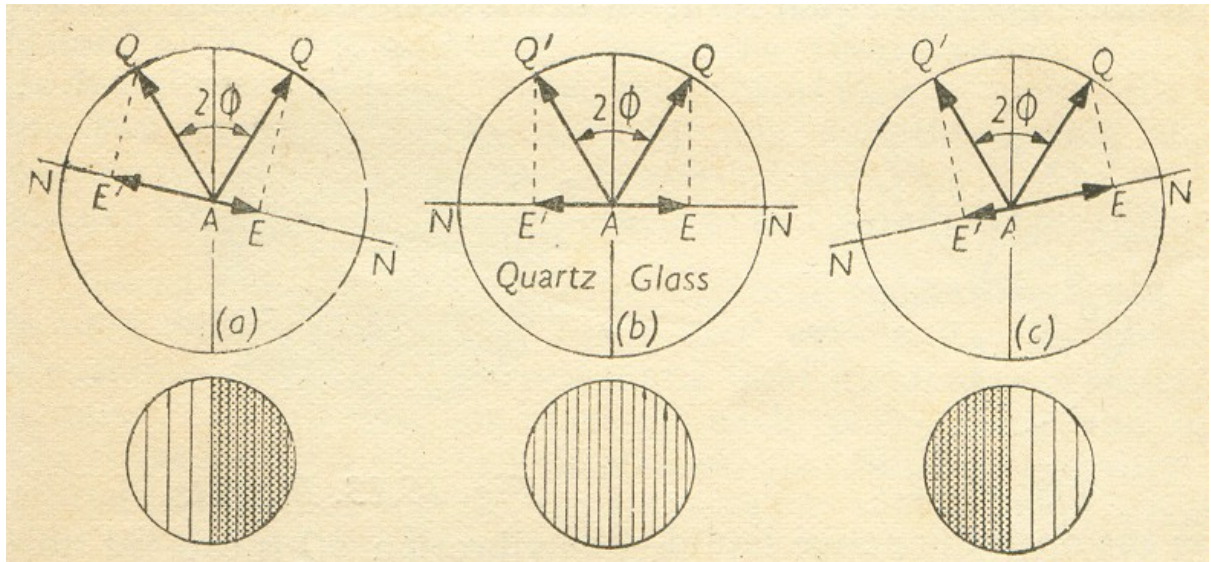

Fig. 15 Principle of half shade plate

the anticlockwise direction from the setting causes the glass portion to appear brighter than the quartz. Thus, we can accurately set the analysing Nicol so that the two halves, of the field are equally bright.

The angle  $2\phi$  between AQ and AQ' is called the half shadow angle. This angle can be varied by rotating the polarizing Nicol about its own axis. The sensitiveness depends upon the magnitude of this angle and upon the intensity of the source of light. There is a certain minimum half-shadow angle for which half shade plate is very sensitive.

### 10. He-Ne Laser

The He-Ne laser is the most widely used laser with continuous power output in the range of a fraction of mW to tens of mW. dependence on the discharge current.

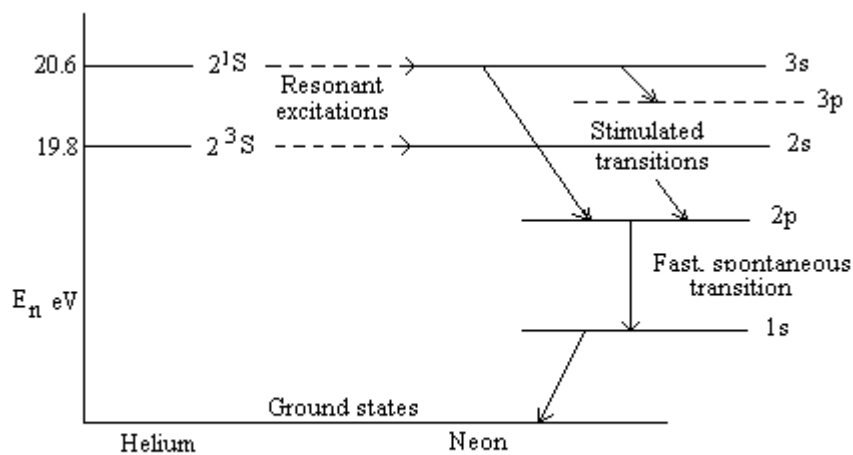

Fig. 16 Energy level diagram for He-Ne laser

The power supplies are therefore matched with the tube.

The following is a simplistic description of the atomic mechanisms generating stimulated photons. The relevant part of the energy level diagrams for helium and neon is given in Figure 16.

Helium atoms are first excited to the  $2^1S$  and  $2^3S$  metastable states in an electrical discharge. The metastable atoms then collide with ground-state neon atoms, exciting them to the  $2s$  and  $3s$  states, respectively. Three stimulated transitions are possible in neon:  $3s \rightarrow 3p$  (emitting at  $\lambda 3.39 \mu\text{m}$ ),  $3s \rightarrow 2p$  ( $\lambda 632.8 \text{ nm}$ ) and  $2s \rightarrow 2p$  ( $\lambda 1.15 \mu\text{m}$ ); the  $3s \rightarrow 2p$  transition gives the characteristic red laser light. (The  $3.39 \mu\text{m}$  infrared radiation can be strongly absorbed by glass elements.) The lasing action depends on keeping the  $2p$  and  $3p$  states unpopulated. This is achieved by having a fast decay route to the  $1s$  state, which is relatively empty. The return to the ground state is achieved via collisions with the walls of the discharge tube.

The gas tube may have Brewster windows inserted into the resonant cavity to plane-polarize the laser output, the cheaper He-Ne lasers do not. In the latter case, the beam is randomly polarized.

### ***Questions:***

#### ***On Microscope***

1. What is the basic difference between a microscope and a telescope?
2. What is there in a compound microscope?
3. Where do you use Huygen's eyepiece and Ramsden's eyepiece?
4. Which of the two eyepieces, Ramsden's and Huygen's, gives a superior image?

#### ***On Optical Bench and Parallax***

5. What are the two types of optical bench? For what purposes are they used?
6. Describe briefly an accurate type of optical bench.
7. What is an index error? How is a distance obtained from the difference of the bench scale readings corrected for index error?
8. What do you understand by parallax? How is it eliminated?

#### ***On Spectrometer***

9. What are the essential parts of a spectrometer?
10. What adjustments are necessary to work with the spectrometer?
11. What will happen if the spectrometer is not properly leveled?
12. What do you mean by the focusing of the spectrometer for parallel rays?
13. Why is it necessary to focus the telescope and the collimator for parallel rays?
14. What do you understand by the minimum deviation position, slant position, and normal position of the prism?
15. Explain briefly the theory of Schuster's method.
16. What are the uses of a spectrometer?
17. State the functions of the collimator and the telescope.
18. What is the use of having two verniers associated with the telescope?