

6. Coupled Pendula

Background

Simple harmonic motion

Simple pendulum

Coupled pendula

Aim of the experiment

To Study the normal modes and resonance of coupled pendula.

Apparatus Required

Coupled pendulum set up

Springs

Stop watch

Theory

Two identical pendula each a light rod of length ' l ' supporting a mass ' m ' and coupled by a weightless spring stiffness ' k ' and of natural length equal to the separation of the masses at zero displacement.

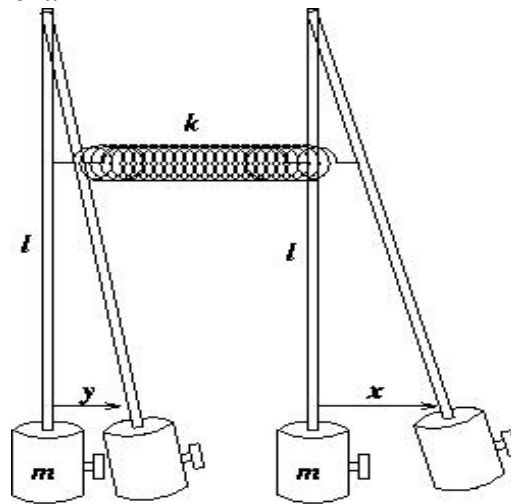

Coupled pendula

Fig. 1

The small oscillations are restricted to the plane of the paper.

If ' x ' and ' y ' are the respective displacement of the two masses, then the equation of motion:

$$m\ddot{x} = -mg \frac{x}{l} - k(x - y) \quad (1)$$

$$\text{and } m\ddot{y} = -mg \frac{y}{l} - k(y - x) \quad (2)$$

Writing natural frequency of each pendula $\omega_0^2 = \frac{g}{l}$, we have

$$\ddot{x} + \omega_0^2 x = -\frac{k}{m}(x - y), \quad (3)$$

$$\ddot{y} + \omega_0^2 y = -\frac{k}{m}(y - x) \quad (4)$$

Adding (3) and (4) we have ,

$$\ddot{x} + \ddot{y} + \omega_0^2(x + y) = 0 \quad (5)$$

Subtracting (4) from (3) gives :

$$\ddot{x} - \ddot{y} + \omega_0^2(x - y) + \frac{2k}{m}(x - y) = 0 \quad (6)$$

Substituting $X = x + y$ in (5) and $Y = x - y$ in (6) respectively, we obtain the following two equations :

$$\ddot{X} + \omega_0^2 X = 0 \quad (7)$$

and

$$\ddot{Y} + \left(\omega_0^2 + \frac{2k}{m} \right) Y = 0 \quad (8)$$

The equation (7) and (8) are equations of simple harmonic motion with natural angular frequencies ω_0 and $\omega_1 = \sqrt{\omega_0^2 + \frac{2k}{m}}$ respectively.

Case I : In-phase mode :

Now if $Y = 0, x = y$ at all times and the motion is completely governed by equation (7) and frequency of oscillation is the same as that of either independent pendulum and spring has no effect. This is due to the fact that both the oscillations are oscillating in phase and the spring is unstretched/uncompressed all the time and hence always maintaining its natural length. See Fig (2).

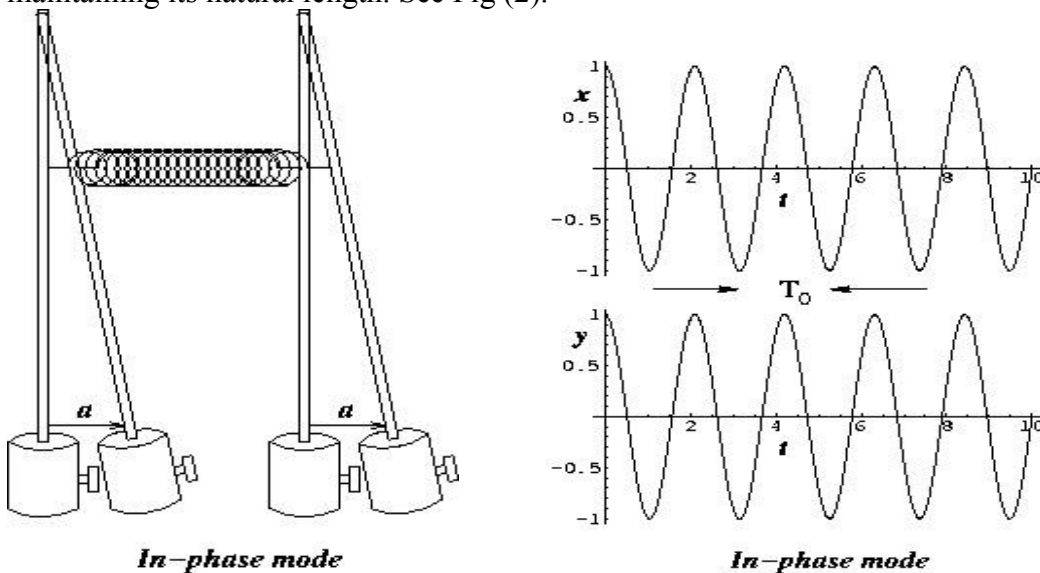

Fig. 2

Case II : Out-of phase mode :

If $X=0, x=-y$ for all time, then the motion will be completely described by equation (8). The frequency of oscillation in this case is greater than that of natural frequency of independent pendulum because the spring is either stretched or compressed. The pendula are always out of phase. See Fig (3).

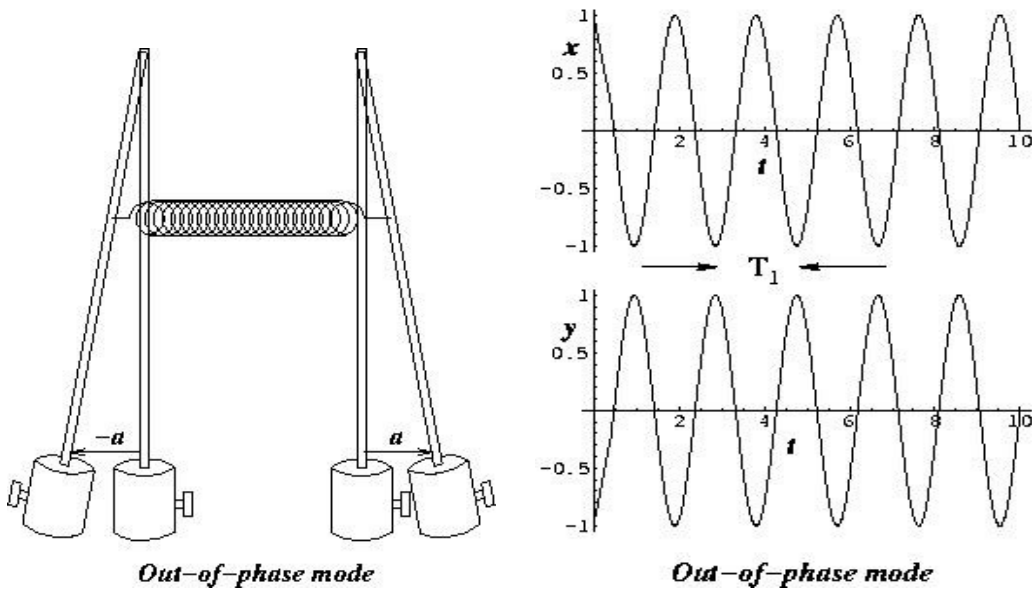

Fig. 3

The above two modes of coupled pendula are called the “normal modes” of vibration. The frequencies ω_0 and $\omega_1 = \sqrt{\omega_0^2 + \frac{2k}{m}}$ are known as the “normal frequencies”. In normal mode all components of the system oscillate with the same normal frequency.

Any arbitrary oscillation of the system is actually a linear combination of these two normal modes.

In the following we shall study one such oscillation called “Resonance”.

Case : III : Resonance

In Resonance we set the system in motion by displacing the right hand mass a distance, $x = 2a$ (or left hand mass a distance $y = -2a$). See Fig (4).

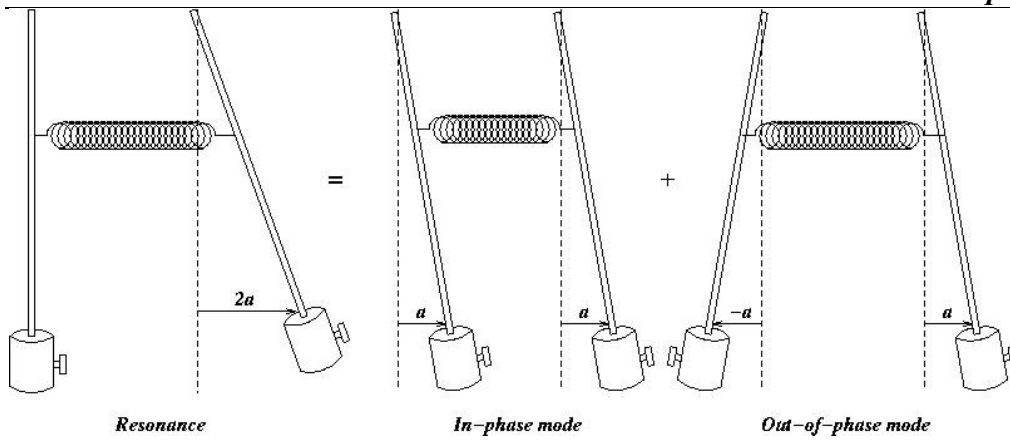

Fig. 4

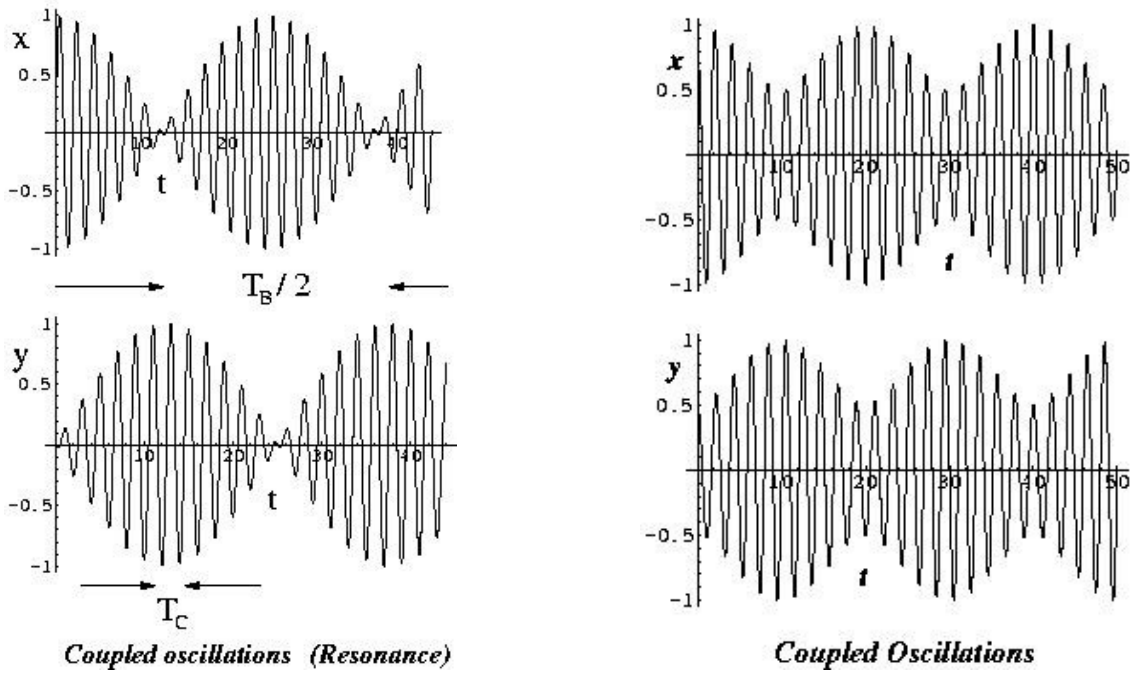

Fig. 5

The general solutions of the equations (7) and (8) are the following :

$$X = x + y = X_0 \cos(\omega_0 t + \phi_1) \tag{9}$$

$$Y = x - y = Y_0 \cos(\omega_1 t + \phi_2) \tag{10}$$

Where ,

$\omega_1^2 = \omega_0^2 + \frac{2k}{m}$. For resonance we choose amplitude $X_0 = Y_0 = 2a$ and phases $\phi_1 = \phi_2 = 0$, the displacement of the right pendulum is given by:

$$\begin{aligned}
 x &= \frac{1}{2}(X + Y) = a\cos\omega_0 t + a\cos\omega_1 t \\
 &= 2a\cos\frac{(\omega_1 - \omega_0)t}{2} \cos\frac{(\omega_1 + \omega_0)t}{2}
 \end{aligned} \tag{11}$$

Similarly the displacement of left pendulum is

$$\begin{aligned}
 y &= \frac{1}{2}(X - Y) = a\cos\omega_0 t - a\cos\omega_1 t \\
 y &= 2a\sin\frac{(\omega_1 - \omega_0)t}{2} \sin\frac{(\omega_1 + \omega_0)t}{2}
 \end{aligned} \tag{12}$$

Figure (4) shows that our initial displacement $x = 2a$ and $y = 0$ at $t = 0$ is a combination of “inphase” mode and “out of phase” mode in equal proportion. The plots of the displacements of individual masses with time for different modes are shown in Fig.5. It can be seen from eqn. (7) and (8) (or from the plot) that the energy of one oscillator is transferred to the other repeatedly. Complete energy exchange is only possible when the masses are identical and the ratio $\frac{(\omega_1 + \omega_0)}{(\omega_1 - \omega_0)}$ is an integer, otherwise

neither will ever be quite stationary.

In each plot we find that there are two frequencies involved. One is the higher frequency (low time period) of oscillations of individual masses. We call this frequency as $\omega_c = \frac{(\omega_0 + \omega_1)}{2}$. This slow variation of amplitude at half the normal mode frequency difference is the phenomenon of “beats” which occur between two oscillations of nearly equal frequencies. We call this frequency as “beats” frequency $\omega_B = \frac{\omega_1 - \omega_0}{2}$. The second one is the lower frequency by which the amplitude of oscillation varies. This is seen by taking the envelope of the amplitude at various times.

$$\text{In phase time period, } T_0 = \frac{2\pi}{\omega_0}$$

$$\text{Out of phase time period, } T_1 = \frac{2\pi}{\omega_1}$$

$$\text{Time period for coupled oscillator, } T_c = \frac{4\pi}{\omega_0 + \omega_1};$$

$$\text{Time period for the beats } T_B = \frac{4\pi}{\omega_1 - \omega_0}$$

$$\text{Or, } T_c = 2 \frac{T_0 T_1}{T_0 + T_1}$$

And
$$T_B = 2 \frac{T_0 T_1}{T_0 - T_1}$$

The degree of coupling is defined by

$$\chi = \frac{\omega_1^2 - \omega_0^2}{\omega_1^2 + \omega_0^2} = \frac{T_0^2 - T_1^2}{T_0^2 + T_1^2}$$

Procedure

1. The two pendula are uncoupled. Set the timeperiod of oscillation of each single separated pendulum equal by properly adjusting the small screws on top and the masses at bottom. This should be done by measuring time for 50 – 100 oscillations.
2. After coupling the two pendula with a spring both are impelled equally in the same direction and the time period of oscillation $T_0 \left(= \frac{2\pi}{\omega_0} \right)$ is measured for 100 oscillations.
3. The connected pendula are impelled equally in opposite directions and the time period of oscillations $T_1 \left(= \frac{2\pi}{\omega_1} \right)$ is noted down for 100 oscillations.
4. One of the pendula left in rest, the other impelled and the time period of oscillation of the coupled oscillations (Beats oscillations) T_c is measured for 100 oscillations.
5. The time period T_B for beats is measured by observing one of the pendula becoming stand still 5-6 times.
6. The value for T_c and T_B are calculated and compared with the measured values.
7. The degree of coupling is to be calculated .
8. The steps 2 to 7 are repeated for pendula coupled with another spring of different stiffness

Observations & Calculations

Least count of the stop watch :

Before Coupling : Spring 1

Time period of pendulum 1 :

Time period of pendulum 2

Before Coupling : Spring 2

Time period of pendulum 1

Time period of pendulum 2

After Coupling

		Measured Values of Time Period				Calculated Values		
Sl. No		In Phase mode (sec)	Out of Phase mode (sec)	Coupled mode (sec)	Beats (sec)	$T_c = \frac{2T_0T_1}{T_0 + T_1}$ (sec)	$T_B = \frac{2T_0T_1}{T_0 - T_1}$ (sec)	Degree of Coupling $\chi = \frac{T_0^2 - T_1^2}{T_0^2 + T_1^2}$
		1	Spring 1	$T_0 =$ 1. 2. 3. Av. $T_0 =$	$T_1 =$ 1. 2. 3. Av. $T_1 =$	$T_c =$ 1. 2. 3. Av. $T_c =$	$T_B =$ 1. 2. 3. Av. $T_B =$	
2	Spring 2	$T_0 =$ 1. 2. 3. Av. $T_0 =$	$T_1 =$ 1. 2. 3. Av. $T_1 =$	$T_c =$ 1. 2. 3. Av. $T_c =$	$T_B =$ 1. 2. 3. Av. $T_B =$			

Precautions

- 1) The independent pendula should be adjusted first with the help of moving masses to have approximately equal oscillation time periods.
- 2) Amplitude of oscillations should be kept small, i.e the angular amplitude should be kept below 10° .
- 3) Time should be noted for large no. of oscillations, i.e 100 or more.
- 4) Spring should be kept at its natural length. It should not be too loose either otherwise a sag will be produced in the spring.

Questions & Discussions :

- 1) Do you agree with the equations of motion (1) & (2) for the system shown in Fig. 1 or the apparatus you are using ? If yes, justify, if no give reasons.
- 2) Identify sources of errors creeping in this experiment and discuss the remedies.

Reference :

The Physics vibrations and waves, H.J. Pain